



Pallet Stackers

D06 – D10 | D08 M

Capacity 0.6 t – 1.0 t | Series 1162

PB

ION

Versatile maneuvering talent

- Compact pedestrian double stacker for transporting goods over short to medium distances
- Versatile use in busy loading areas, in supermarkets or in warehouses
- Lifting height up to 2 meters and load capacity up to 2000 kilograms
- Simultaneous handling of two pallets possible
- Compact mono mast version with optimum visibility, ideal for retail applications (D08 M)
- Innovative 5-point configuration with castor wheels ensures maximum stability

TECHNICAL DATA (according to VDI 2198)

			Linde MH	Linde MH	Linde MH	Linde MH	
			D06	D08	D08 M	D10	
Characteristics	1.1	Manufacturer (abbreviation)		Linde MH	Linde MH	Linde MH	Linde MH
	1.2	Manufacturer's type designation		D06	D08	D08 M	D10
	1.2a	Series		1162-00	1162-00	1162-00	1162-00
	1.3	Drive		Battery	Battery	Battery	Battery
	1.4	Operation		Pedestrian	Pedestrian	Pedestrian	Pedestrian
	1.5	Rated capacity/rated load	Q (t)	1.6/(0.6 + 1.0)	1.8/(0.8 + 1.0)	1.8/(0.8 + 1.0)	2.0/(1.0 + 1.0)
	1.6	Load centre distance	c (mm)	600	600	600	600
	1.8	Load distance, centre of drive axle to fork	x (mm)	873/936 ⁽¹²⁾	873/936 ⁽¹²⁾	859/922 ⁽¹²⁾	874/937 ⁽¹²⁾
	1.9	Wheelbase	y (mm)	1306/1369 ⁽¹²⁾⁽³⁾	1306/1369 ⁽¹²⁾⁽³⁾	1306/1369 ⁽¹²⁾⁽³⁾	1425/1488 ⁽¹²⁾⁽¹⁶⁾
Weight	2.1	Service weight	kg	638 ⁽⁹⁾	664 ⁽⁹⁾	621 ⁽⁹⁾	830 ⁽⁹⁾
	2.2	Axle loading, laden front/rear	kg	797/1441 ⁽⁹⁾	858/1606 ⁽⁹⁾	808/1613 ⁽⁹⁾	986/1844 ⁽⁹⁾
	2.3	Axle loading, unladen front/rear	kg	463/175 ⁽⁹⁾	482/182 ⁽⁹⁾	451/170 ⁽⁹⁾	601/229 ⁽⁹⁾
Tyres/chassis	3.1	Tyres: solid rubber, superelastic, pneumatic, polyurethane		Polyurethane	Polyurethane	Polyurethane	Polyurethane
	3.2	Tyre size, front		Ø 230 × 75	Ø 230 × 75	Ø 230 × 75	Ø 230 × 75
	3.3	Tyre size, rear		Ø 85 × 80 (Ø 85 × 60) ⁽⁶⁾	Ø 85 × 80 (Ø 85 × 60) ⁽⁶⁾	Ø 85 × 80 (Ø 85 × 60) ⁽⁶⁾	Ø 85 × 80 (Ø 85 × 60) ⁽⁶⁾
	3.4	Additional wheels (dimensions)		2x Ø 125 × 40	2x Ø 125 × 40	2x Ø 125 × 40	2x Ø 125 × 40
	3.5	Wheels, number front/rear (x = driven wheels)		1x + 2/2 (1x + 2/4) ⁽⁹⁾	1x + 2/2 (1x + 2/4) ⁽⁹⁾	1x + 2/2 (1x + 2/4) ⁽⁹⁾	1x + 2/2 (1x + 2/4) ⁽⁹⁾
	3.6	Tread, front	b10 (mm)	482 ⁽²⁾	482 ⁽²⁾	482 ⁽²⁾	482 ⁽²⁾
	3.7	Tread, rear	b11 (mm)	338/353/378 ⁽²⁾⁽⁷⁾	338/353/378 ⁽²⁾⁽⁷⁾	353/378 ⁽²⁾⁽⁷⁾	353/378 ⁽²⁾⁽⁷⁾
Dimensions	4.2	Mast height, lowered	h1 (mm)	1536	2060	1988	1474
	4.3	Free lift	h2 (mm)	989	1730	1460	150
	4.4	Lift	h3 (mm)	989 ⁽²⁾	1730 ⁽²⁾	1590 ⁽²⁾	2024 ⁽²⁾
	4.5	Mast height, extended	h4 (mm)	1661	2185	2220	2270
	4.6	Initial lift	h5 (mm)	125	125	125	125
	4.9	Height drawbar in driving position min./max.	h14 (mm)	810/1205 ⁽²⁾	810/1205 ⁽²⁾	810/1205 ⁽²⁾	810/1205 ⁽²⁾
	4.10	Height of wheel arms	h8 (mm)	60	60	60	60
	4.15	Height, lowered	h13 (mm)	86 ⁽⁸⁾	86 ⁽⁸⁾	86 ⁽⁸⁾	86 ⁽⁸⁾
	4.19	Overall length	l1 (mm)	1742 ⁽³⁾	1742 ⁽³⁾	1756 ⁽²⁾	1860 ⁽¹⁶⁾
	4.20	Length to fork face	l2 (mm)	592 ⁽³⁾	592 ⁽³⁾	606 ⁽²⁾	710 ⁽¹⁶⁾
	4.21	Overall width	b1/b2 (mm)	720 ⁽²⁾	720 ⁽²⁾	720 ⁽²⁾	720 ⁽²⁾
	4.22	Fork dimensions DIN ISO 2331	s/e/l (mm)	55/182/1150	55/182/1150	55/182/1150	55/182/1150
	4.24	Fork carriage width	b3 (mm)	514/529/554	514/529/554	650	710
	4.25	Fork spread	b5 (mm)	520/535/560	520/535/560	535/560	560
	4.31	Ground clearance, laden, below mast	m1 (mm)	20/145 ⁽¹⁰⁾	20/145 ⁽¹⁰⁾	20/145 ⁽¹⁰⁾	20/145 ⁽¹⁰⁾
4.32	Ground clearance, centre of wheelbase	m2 (mm)	20/145 ⁽¹⁰⁾	20/145 ⁽¹⁰⁾	20/145 ⁽¹⁰⁾	20/145 ⁽¹⁰⁾	
4.34.1	Aisle width for pallets 1000 × 1200 crossways	Ast (mm)	2325 ⁽¹¹⁾⁽¹²⁾	2325 ⁽¹¹⁾⁽¹²⁾	2328 ⁽¹¹⁾⁽¹²⁾	2444 ⁽¹¹⁾⁽¹²⁾⁽¹⁶⁾	
4.34.2	Aisle width for pallets 800 × 1200 lengthways	Ast (mm)	2229 ⁽¹¹⁾⁽¹²⁾	2229 ⁽¹¹⁾⁽¹²⁾	2328 ⁽¹¹⁾⁽¹²⁾	2347 ⁽¹¹⁾⁽¹²⁾⁽¹⁶⁾	
4.35	Turning radius	Wa (mm)	1512/1575 ⁽¹³⁾	1512/1575 ⁽¹³⁾	1512/1575 ⁽¹²⁾	1631/1694 ⁽¹⁶⁾	
Performance	5.1	Travel speed, laden/unladen	km/h	6/6 ⁽³⁾	6/6 ⁽³⁾	5/5 ⁽³⁾	5/5 ⁽³⁾
	5.1.1	Travel speed, laden/unladen, backwards	km/h	6/6 ⁽³⁾	6/6 ⁽³⁾	5/5 ⁽³⁾	5/5 ⁽³⁾
	5.2	Lifting speed, laden/unladen	m/s	0.094/0.152 ⁽⁵⁾	0.094/0.152 ⁽⁵⁾	0.129/0.197 ⁽⁵⁾	0.12/0.183 ⁽⁵⁾
	5.3	Lowering speed, laden/unladen	m/s	0.352/0.133 ⁽⁵⁾	0.352/0.133 ⁽⁵⁾	0.331/0.201 ⁽⁵⁾	0.272/0.278 ⁽⁵⁾
	5.8	Max. gradeability, laden/unladen	%	10.0/20.0	10.0/20.0	10.0/20.0	10.0/20.0
	5.9	Acceleration time, laden/unladen	s	7.0/6.6	7.3/7.0	7.0/6.5	7.3/6.6
	5.10	Service brake		Electromagnetic	Electromagnetic	Electromagnetic	Electromagnetic
Electric-engine	6.1	Drive motor rating S2 60 min	kW	1.3	1.3	1.3	1.3
	6.2	Lift motor rating at S3 15%	kW	1.2	1.2	1.2	1.2
	6.3	Battery according to DIN 43531/35/36 A, B, C, no		Li-ION compact	Li-ION compact	Li-ION compact	2 PzS-B
	6.4	Battery voltage/nominal capacity K5	(V)/(Ah) or kWh	24/62 (125) ⁽¹⁴⁾	24/62 (125) ⁽¹⁴⁾	24/62 (125) ⁽¹⁴⁾	24/150
	6.5	Battery weight (±5%)	kg	14/23 ⁽⁹⁾	14/23 ⁽⁹⁾	14/23 ⁽⁹⁾	134/154 ⁽⁹⁾
	6.6	Energy consumption according to DIN EN 16796	kWh/h	0.51	0.59	0.64	0.68
	6.7	Turnover output according to VDI 2198	t/h	21.0	26.0	29.0	32.0
	6.8	Turnover efficiency according to VDI 2198	t/kWh	28	32	45	37
Additional data	10.7	Sound pressure level LpAZ (at the operator's seat)	dB(A)	58 ⁽¹⁵⁾	58 ⁽¹⁵⁾	61 ⁽¹⁵⁾	58 ⁽¹⁵⁾

1) Forks upraised/lowered

2) (±5 mm)

3) +50 mm = BS battery (2 PzS-B); +105 mm = 2 PzS battery

4) Figures with battery, see line 6.4/6.5.

5) (±10%)

6) Figures in parenthesis with tandem load wheels.

7) Depending on the forks spread; see 4.25

8) (-0/+5 mm)

9) min./max.

10) (±2 mm)

11) Including a 200 mm (min.) operating aisle clearance.

12) With creep speed = tiller in vertical position

13) (±5%)

14) (Option)

15) (±2.5)

16) +0 mm = BS battery (2 PzS-B); +55 mm = 2 PzS battery

D06

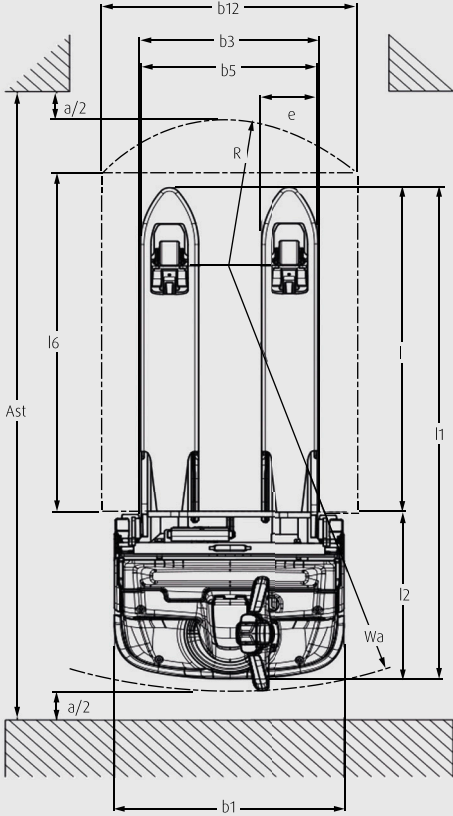
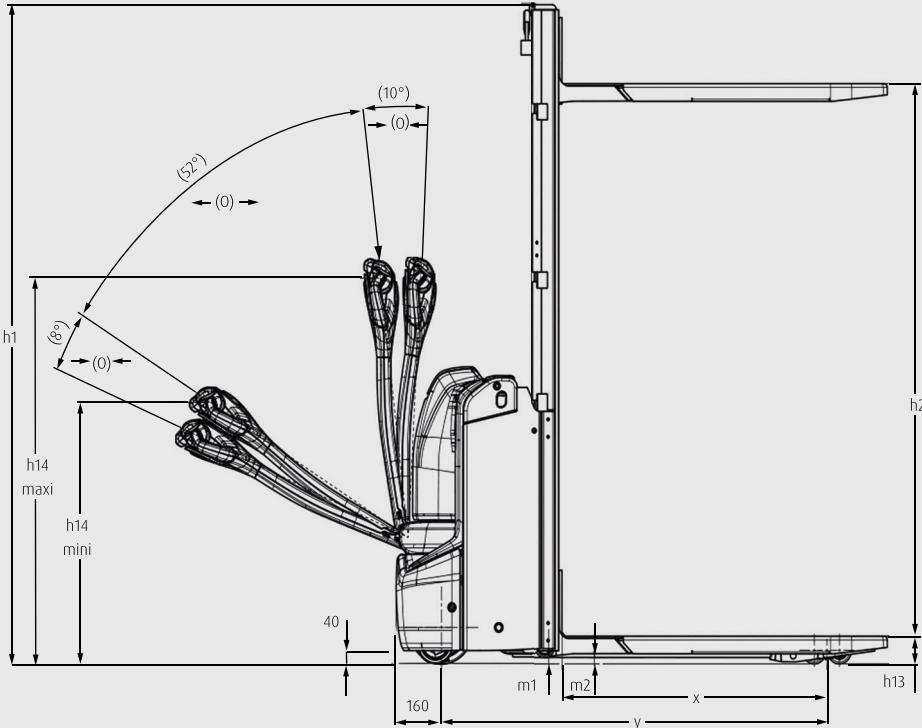

D08 M

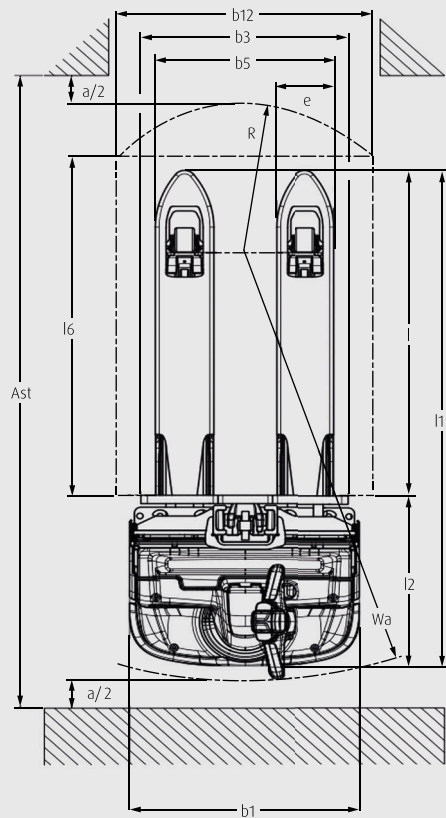
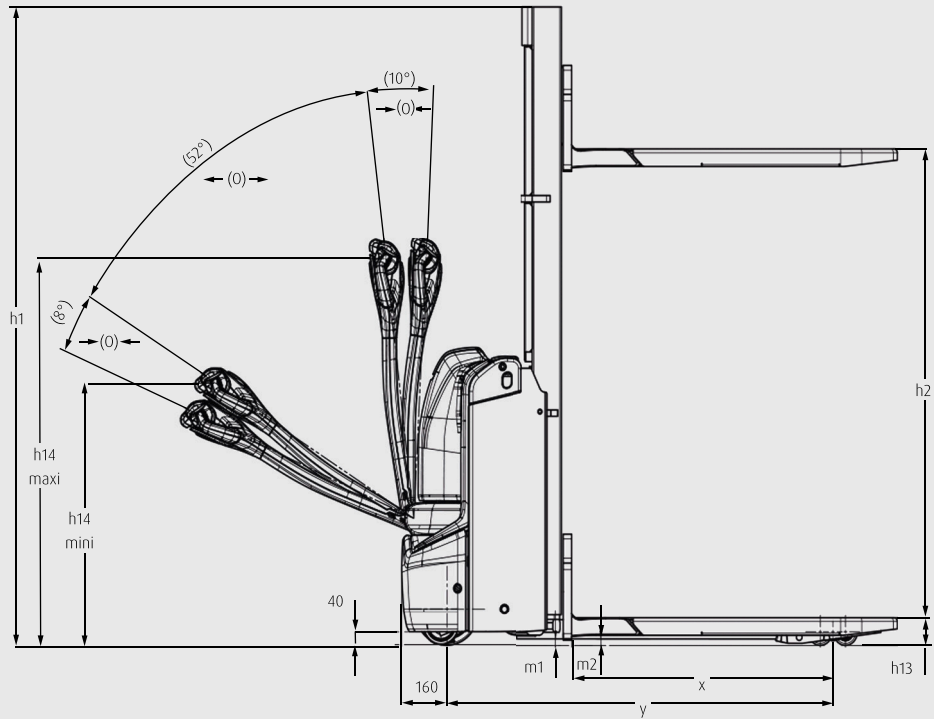

D10

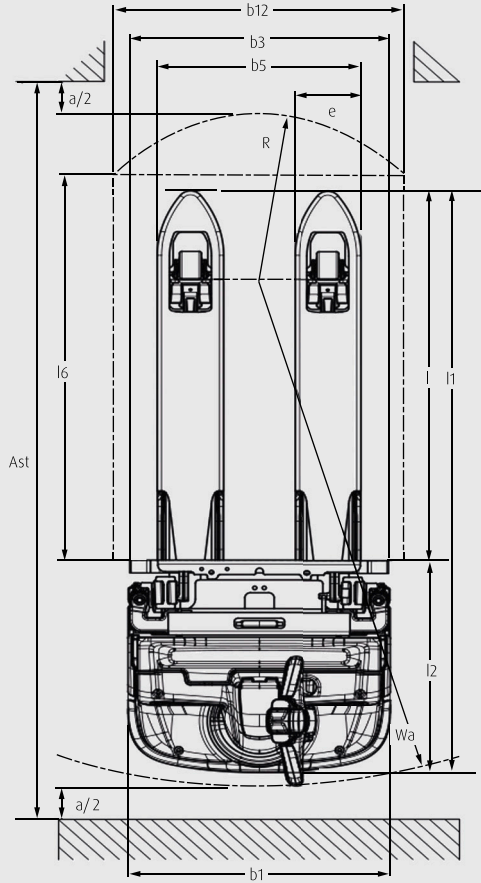
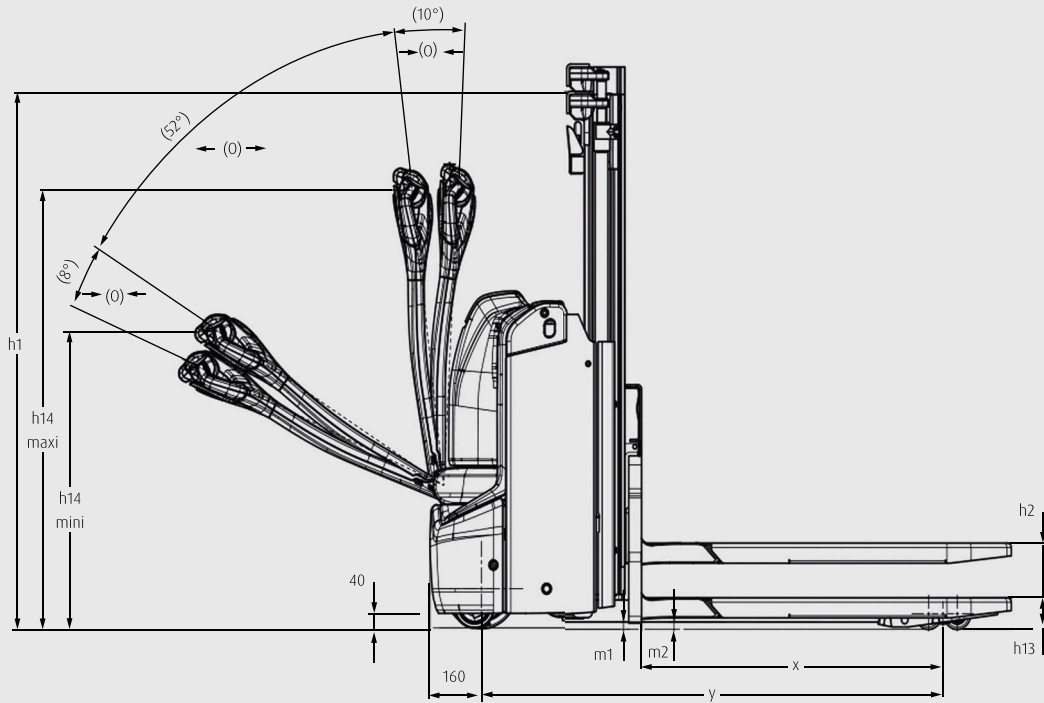

MAST TABLES

STANDARD MAST (in mm)

Lift	h3: 1574		h3: 1724		h3: 2024	
Height measurements	h1: 1240	h2: 150	h1: 1315	h2: 150	h1: 1465	h2: 150
Manufacturer's type designation						
D06	○		○		○	
D08	○		○		○	
D10	○		○		○	

SIMPLEX MAST (in mm)

Lift	h3: 989		h3: 1730		h3: 958		h3: 1590	
Height measurements	h1: 1532	h2: 150	h1: 2056	h2: 150	h1: 1635	h2: 150	h1: 1989	h2: 150
Manufacturer's type designation								
D06	○		○		—		—	
D08	○		○		—		—	
D08 M*	—		—		○		○	

○ Optional equipment — Not available

h1: Mast height, lowered

h2: Free lift

h3: Lift

* Mono mast

STANDARD AND OPTIONAL EQUIPMENT

Manufacturer's type designation/equipment		D06	D08	D08 M	D10
Safety	Active foot bumper – assistant system for foot protection	○	○	○	○
	Long tiller and low chassis skirt	●	●	●	●
	Automatic speed reduction when cornering	●	●	●	●
	Easily accessible emergency stop button	●	●	●	●
	Buzzer – preferable where low noise emission required	●	●	●	●
	Horn – preferable for noisy environment	○	○	○	○
	Key switch	●	●	●	●
	Log in PIN code	○	○	○	○
Linde BlueSpot – visual warning of truck presence		○	○	○	○
Service	CAN bus technology	●	●	●	●
Digitalisation	Data transmission online	○	○	○	○
	Data transmission Wifi	○	○	○	○
	Linde connect.ac pre-shift check – app for operator to report truck condition before use	○	○	○	○
	Linde connect.dt crash detection – allows electronic impact damage monitoring	○	○	○	○
Operation/load handling	Automatic lifting – up and down	○	○	○	○
	Extra side buttons – up and down	○	○	–	○
	Lift end stop sensor	○	○	○	○
	OptiLift fully proportional lifting function	●	●	●	●
	Soft landing of forks	○	○	○	○
	Proportional speed control – speed depending on tiller angle	○	○	○	○
	Creep speed – for operation with tiller in vertical position	●	●	●	●
	Environment	Coldstore protection -35°C (in/out)	○	○	○
Workplace	Multifunction display – hour meter, maintenance indication, battery discharge indicator and internal fault code indication	●	●	●	●
	Ergonomic tiller head with easy access to the controls	●	●	●	●
	Load backrest h = 700 mm, or h = 900 mm, from top of forks	○	○	○	○
	Accessory support	○	○	○	○
	Support clipboard and scanner	○	○	○	○
	Metallic battery cover	○	○	○	○
Mast	Standard mast	○	○	–	○
	Simplex mast	○	○	–	–
	Mono mast simplex	–	–	○	–
	Mast protection, polycarbonate	●	●	○	●
	Mast protection, mesh	○	○	–	○
	Mast protection, metallic	–	–	●	–
Attach-ment/ forks	Fork width : 520 mm, 535 mm, 540 mm, 560 mm	○	○	○	○
	Fork length : 1150 mm, 1190 mm, with overhang 55 mm	○	○	○	○
Axles and tyres	Drive wheel, standard duty	●	●	●	●
	Drive wheel heavy duty, high grip	○	○	○	○
	Single load wheel, polyurethane	●	●	●	●
	Tandem load wheels, polyurethane	○	○	○	○
	Tandem load wheels, polyurethane greasable	○	○	○	○
	Auto-adjustable castor wheels	●	●	●	●
Drive and brake system	Maintenance-free AC motor	●	●	●	●
	Electromagnetic braking system	●	●	●	●
	Battery compartment, vertical compact	○	○	●	–
	Battery compartment, 2 PzS-B vertical change	●	●	–	●
	Battery compartment, 2 PzS lateral or vertical change	○	○	–	○
Energy	Li-ION technology available – different battery capacities with front, laterally or vertically mounted opportunity charging plug	○	○	○	○
	Lead-acid battery technology	○	○	–	○
	On-board charger 35 A or 70 A for lead-acid and Li-ION batteries	○	○	○	○
	Li-ION front plug	○	○	○	–
	Li-ION plug, laterally or vertically mounted	○	○	–	○
	External chargers available	○	○	○	○

● Standard equipment ○ Optional equipment – Not available

CHARACTERISTICS



Long, low-mounted tiller arm

Safety

- Long, low-mounted tiller arm enables optimum safety distance from the vehicle
- Deep-drawn chassis protects the operator's feet
- Start-off assistant prevents rollback on inclines
- Specially shaped tiller head for hand protection
- Mono mast (D08 M) provides improved visibility of load and surroundings
- Low chassis skirt and active foot bumper (option) protect the operator



Ergonomic tiller head

Ergonomics

- Control of all functions via the ergonomic tiller head
- One-handed operation of the vehicle possible
- Can also be easily operated with gloves
- Effortless maneuvering in tight spaces
- Storage compartments for work utensils available



D08 M with mono mast

Handling

- OptiLift assistance system ensures precise load handling
- Compact design for optimum maneuverability in confined spaces
- Creep speed function enables effortless and precise movements
- Speed up to 6 km/h for fast and effective work
- Fast opportunity charging with optional on-board charger
- Mono mast facilitates order picking and shelf replenishment (D08 M)



Robust vehicle design

Service

- Robust vehicle design increases reliability
- Easy access to all main components for time-saving service
- Steel-reinforced tiller arm enables tough applications
- CAN bus structure for efficient fault diagnosis
- Long service intervals ensure low maintenance costs

Presented by:

Subject to modification in the interest of progress. Illustrations and technical details could include options and are not binding for actual constructions. All dimensions subject to usual tolerances.



Linde Material Handling GmbH
Carl-von-Linde-Platz | 63743 Aschaffenburg | Germany
Phone + 49 6021 99 0 | Fax + 49 6021 99 1570
www.linde-mh.com | info@linde-mh.com
DS_D06-D10_D08M_1162_en_B_0325

